



REPORT SERVICES POLYTESTS INC.

695-B rue Gaudette

St-Jean-sur-Richelieu, QC, J3B 7S7

REPORT No. P-1609-E

Evaluation of Railing system
Model: Verano Model

Client:
Procam Distribution inc.
780 Vernon, Suite D, Gatineau (QC), J9J 3K5

Attention: Germain Leblanc

GENERAL: This report presents the results of load tests performed on samples provided by client Procam Distribution; all tests were carried out in POLYTESTS laboratory. Results only apply to samples tested. This report may be reproduced in part, except with the permission of POLYTESTS Services Inc.

TABLE OF CONTENT

1 RESULTS.....	1
1.1 GENERAL	1
1.2 PRODUCT LINE AND TEST SAMPLES	1
2 TEST PROGRAM.....	2
2.1 RESULTS.....	2
2.2 TEST DESCRIPTION	3
3 CONCLUSION	3

Appendix A

Appendix B

1 Results

1.1 General

This report covers the load tests performed on representative samples of guard railings in accordance with the requirements of the National Building Code (NBC) 2015 and the Ontario Building Code (OBC) 2012 (9.8.8.2). Evaluation period was done in April 2022

1.2 Product line and test samples

Several specimens of each system of 60- & 72-inches long Verano model from Procam Distribution inc., they were delivered to Services Polytests for testing in April 2022. The testing was done by Alain Lefebvre from POLYTESTS

General:

Material:	Tempered glass 12mm
Model tested:	Verano model (60 inches wide X 48- & 42-inches High) & Verano model (72 inches wide X 48- & 42-inches High).
Model covered:	Verano model from 12 inches width to 60 inches wide with two spigots, over 60 inches wide till 72 inches, three spigots are needed.
Overall Dimension:	1.52 m (60in) long x 1.22 m (48in) high & 1.83 m (72in) long x 1.22 m (48in) high

Product description:

Hand rail:	none
Glass top clamp:	45 mm (1.75in) high X 95 mm (3.75in) long (only required for glass width less than 36 inches, optional for glass wider than 36 inches.
Glass:	1.52 m (60in) long x 1.22 m (48in) High x 12 mm (0.47in) thick 1.83 m (72in) long x 1.22 m (48in) High x 12 mm (0.47in) thick
Glass panel support:	support base 98.4mm (3.875in) X 98.4mm (3.875in) x 160mm (6.3in) height.
Floor fixations:	Wood (Appendix B): four Lag bolt 3/8 in Diameter X 6 in long Concrete (minimum 25 Mpa): Four concrete Hilti anchor 1/4 in. X 3 in. long

2 Test program

Test # 1 The guardrail system shall be designed to resist a horizontal load of 0.5 kN/m or a concentrated load of 1.0 kN applied at any point along the top rail, whichever governs (NBCC 9.8.8.2). For this system, both the distributed 0.5 kN/m and concentrated 1.0 kN loads were applied, with the concentrated load applied at the juncture between the rail and post and at any point of the rail.

Test # 2 The guardrail system shall be designed to resist a 1.5 Kn/m load applied vertically (force directed downward) at the top of the guard (NBCC 9.8.8.2).

Test # 3 Individual elements within the guard, including glass component, must be designed to resist a concentrated load of 0.5kN at any point in the element (NBCC 9.8.8.2). The force was applied at the midpoint of the glass component with plywood of 300mm X 300 mm for installation guard serving not more than 2 dwelling units.

2.1 Results

Loading description	Specified load	1,5 X Factored for live load required	1.1 X Factored Minimum design load required	Test Results (pass or fail)
1.1 Uniformly distributed load applied in the horizontal direction (on 60- & 72-inches length for 48 inches high)	0,50 KN/m	0,75 KN/m	0,825 KN/m	Pass
1.2 Concentrated load applied at any point of the rail in a horizontal direction	1,0 KN	1,5 KN	1,65 KN	Pass
1.3 Concentrated load applied at end of the rail in horizontal direction	1,0 KN	1,5 KN	1.65 KN	Pass
2. Uniformly distributed load applied in the vertical direction	1,5 KN/m	2,25 KN/m	2.48 KN/m	Pass
3. For guards not more than 2 dwelling applied over a maximum width of 300 mm and height of 300 mm	0,5 KN	0,75KN	0.825 KN	Pass

Note: Safety factors of 1.65 have been applied to all load during test series. Tests have been done on three samples.

2.2 Test Description

Loading time: between 15 sec to 30 sec

Load holding time: 1 min minimum

Sample evaluation: Following each test, sample was inspected for signs of failure, component displacement or cracking of structural components that could impair the safety of the product. The product shall remain safe for its intended use after each test. A serviceability testing load is done on each sample following maximum load to ensure the integrity of the assembly.

Loading 1.1: Uniformly distributed load applied in the horizontal direction for outdoor installation deserving less than 2 dwellings (on 60- & 72-inches length for 48 inches high).

Loading 1.3: Concentrated load applied at any point of the rail in a horizontal direction for both 60- & 72-inches length for 48 inches high.

Loading 1.4: Concentrated load applied at end of the rail in horizontal direction for both 60- & 72-inches length for 48 inches high.

Loading 2: Uniformly distributed load applied in the vertical direction

Loading 3: For guards not more than 2 dwelling applied over a maximum width of 300 mm and height of 300 mm on the glass component.

3 Conclusion

Based on the results obtained following testing, Procam Distribution: Verano model meets the factored design load performance requirements as outline in the 2015 National building code of Canada (NBCC); 2012 Ontario Building code (OBC) for use within dwelling and as exterior guards for 60in lengths or less.

Tested by:
Alain Lefebvre



Reported by:
Danick Power, Eng.



Review by:
Gaétan Piedalue, Eng.

Appendix A
Testing details and pictures

1.1 uniformly distributed horizontal load

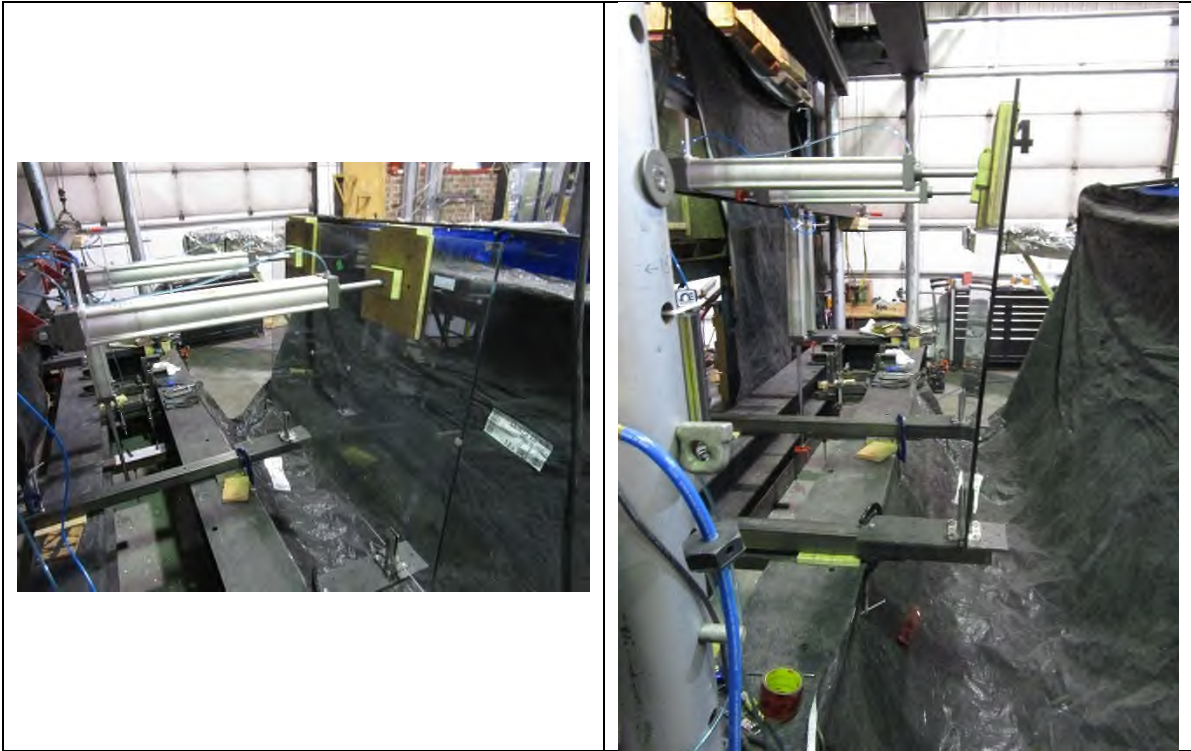

1.2 Concentrated load applied midpoint at the highest point in horizontal direction



1.3 Concentrated load applied end rail at the highest point in horizontal direction



2. uniformly distributed vertical load

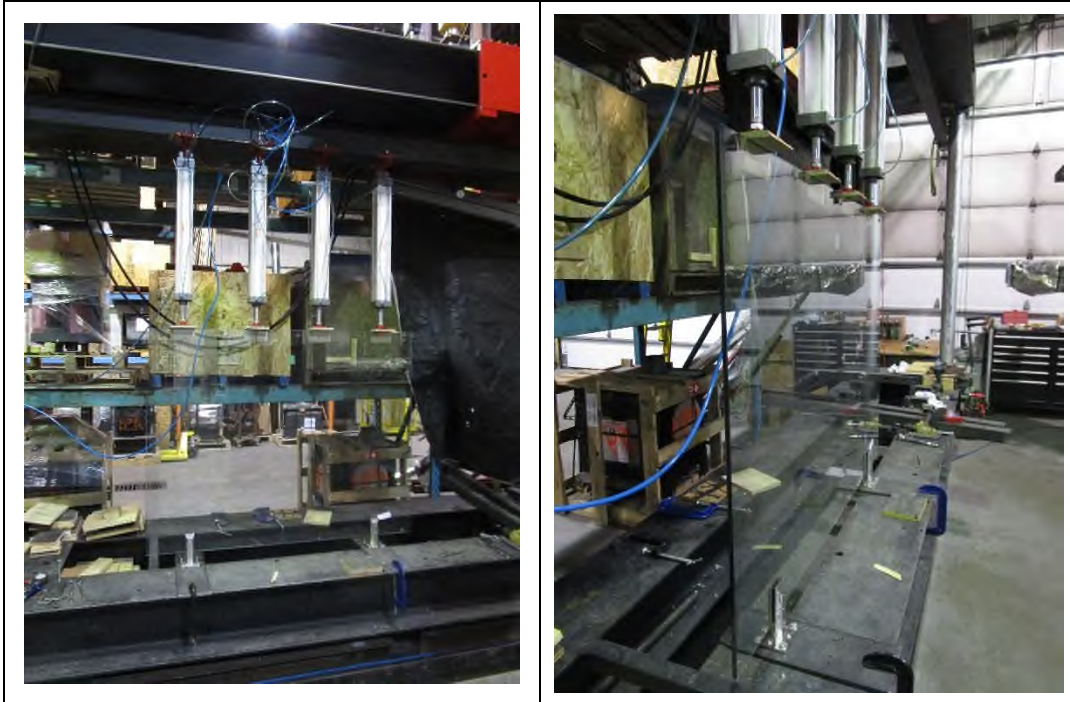



3. Concrete installation testing 25Mpa.





4. Wood Deck installation testing



Anchors description

Wood (see assembly in appendix B)	Concrete (minimum 25 Mpa)
4 X Lag bolt 3/8 – 6in long	4 X Hilti Anchor 1/4in. X 3in long with washer
	

Glass Spigot	Glass Spigot
	

Glass Spigot

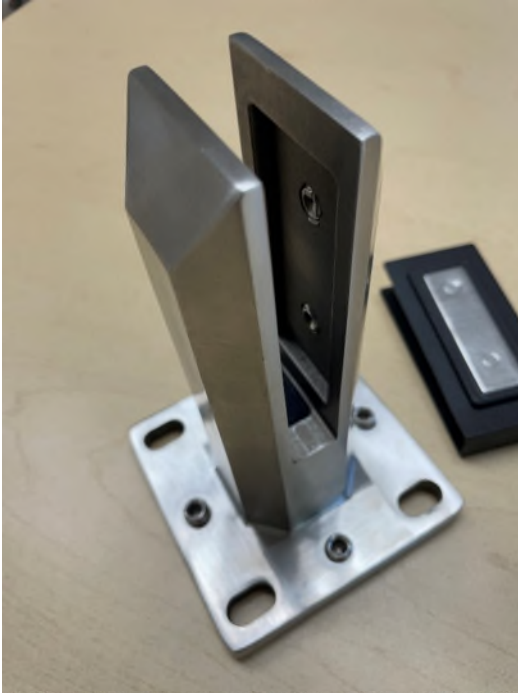

Appendix B
Distributed Drawings
(3 pages)

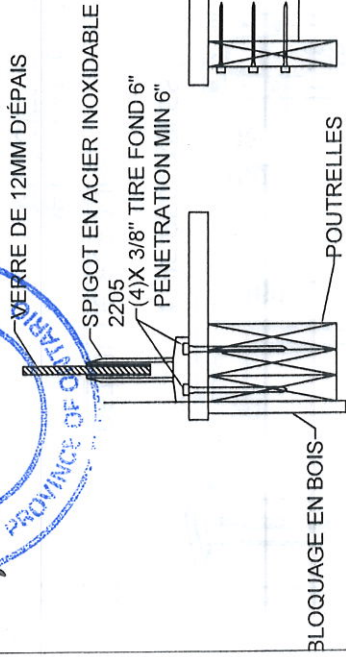

DETAIL SUR POUTRELLE
SECTION A

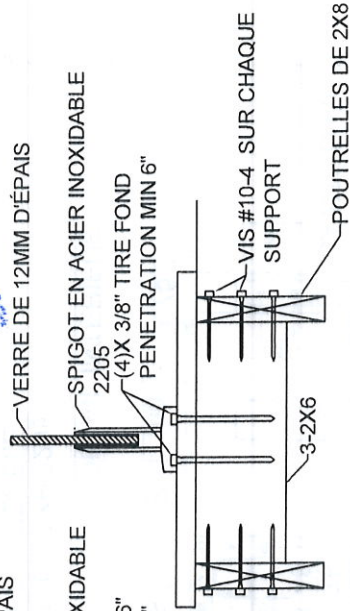

DETAIL AUX DESSUS PLANCHER
SECTION A

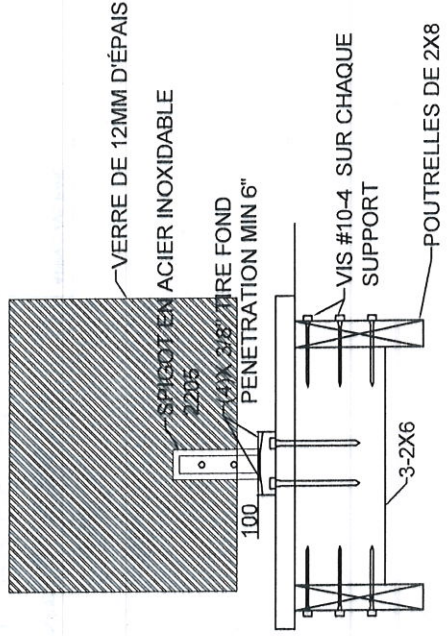

DETAIL AUX DESSUS PLANCHER
SECTION B

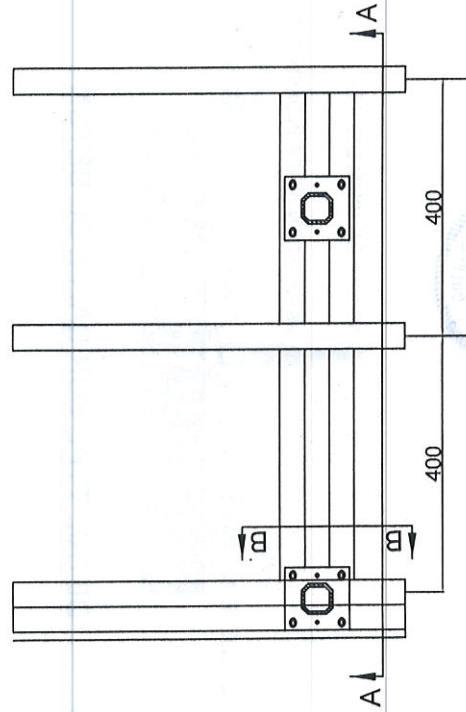

PATIO PLAN

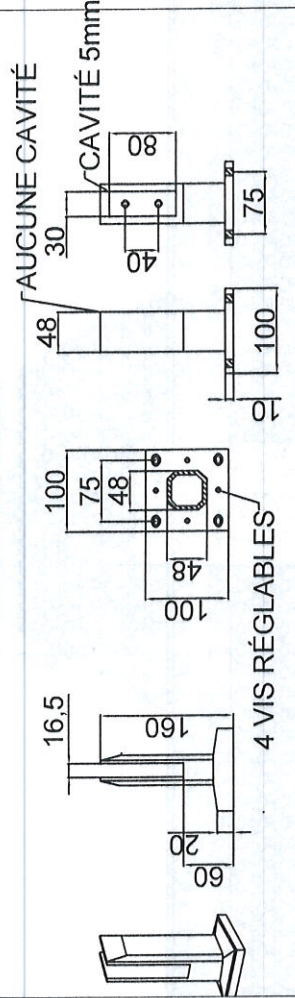

DETAIL DE PLAQUES
DETAIL INTERIEUR

DETAIL SPIGOT TYP 2205
EN ACIER INOXIDABLE

PROCAM
DISTRIBUTION

PROJET:	DETAIL TYPIQUE POUR ANCRAGE POUR BOIS
CONÇU PAR:	C. Martineau
DESSINÉ PAR:	C. Martineau
ÉCHELLE:	N.T.S
DATE:	29 AVRIL 2022
APPROUVÉ PAR:	

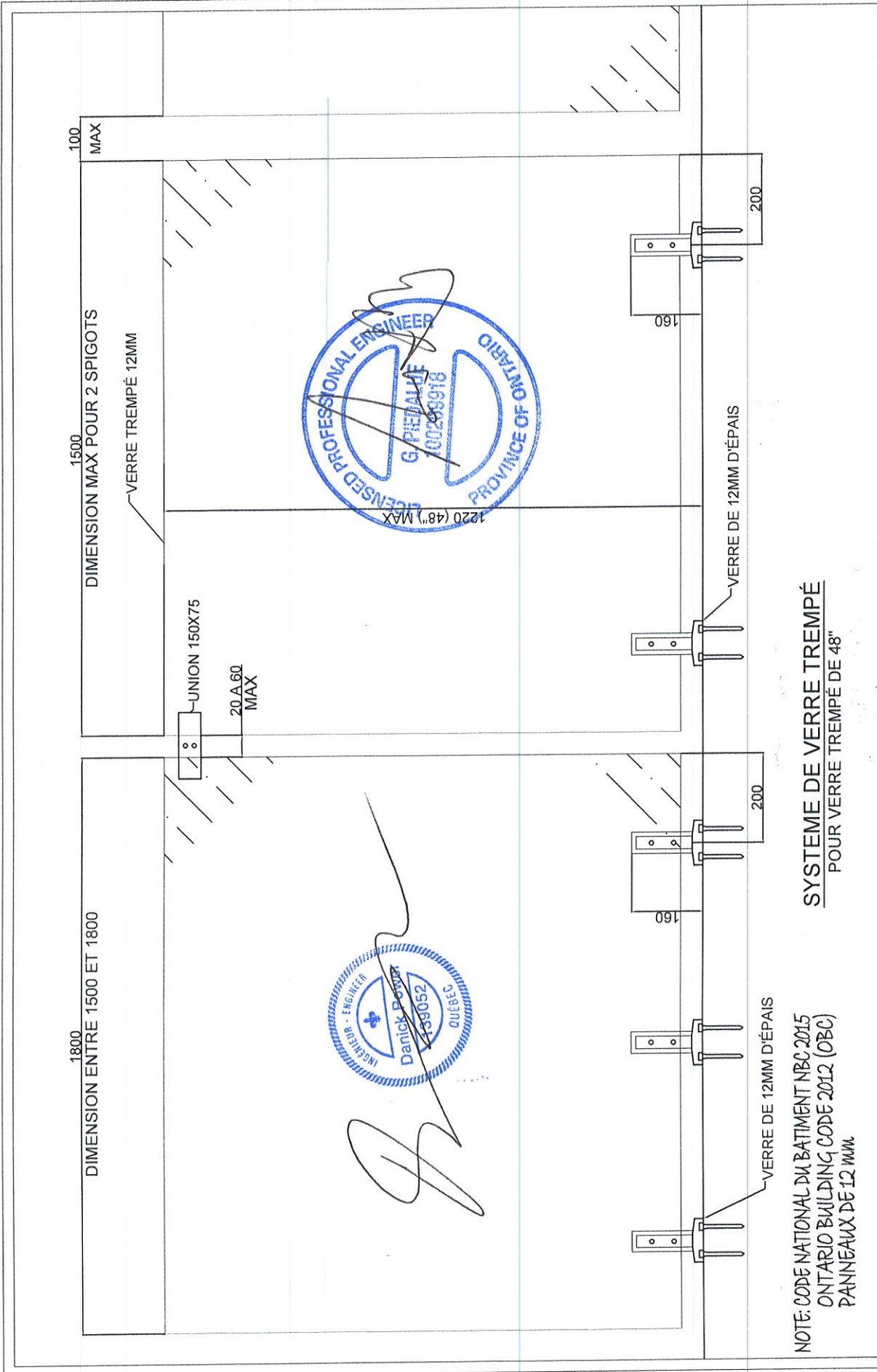

SYSTEME DE VERRE TREMPÉ
 POUR VERRE TREMPÉ DE 48"

PROJET:	SYSTEME DE VERRE TREMPÉ 12MM
CONÇU PAR:	C. MARTINEAU
DESSINÉ PAR:	C. MARTINEAU
ÉCHELLE:	N.T.S.
DATE:	29 AVRIL 2022

APPROUVÉ PAR:

PROCAM[®]
 DISTRIBUTION